

(No Model.)

2 Sheets—Sheet 1.

R. T. HUGGINS.

TRICYCLE.

No. 414,046.

Patented Oct. 29, 1889.

Fig-1

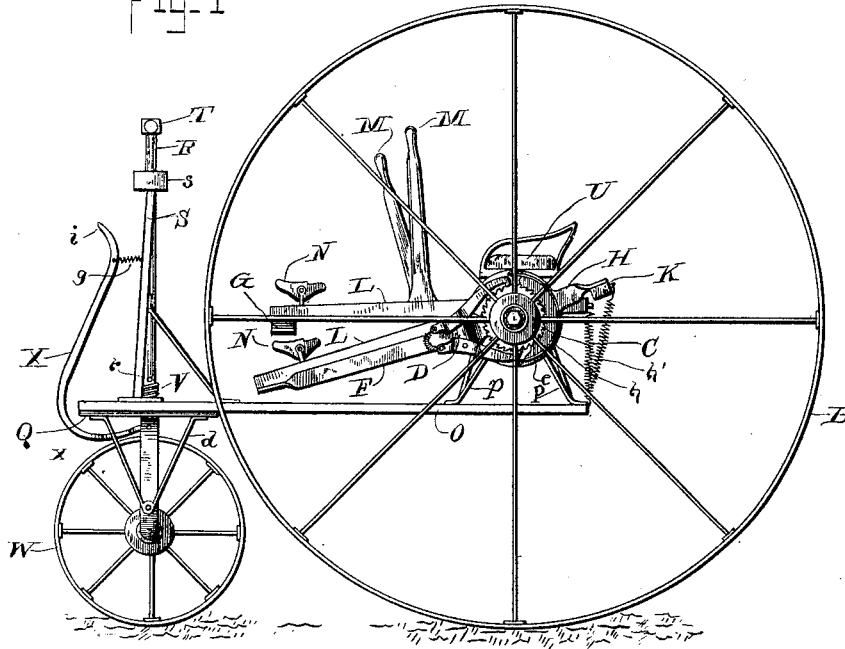
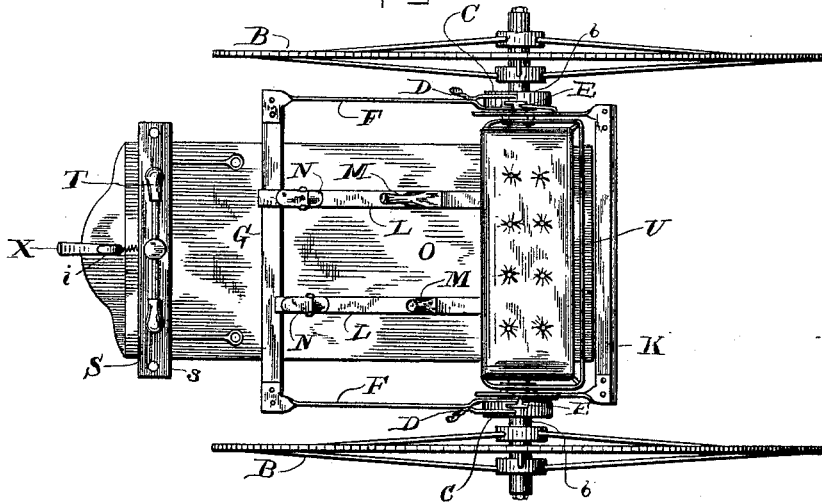

Fig-2



WITNESSES:

F. L. Ourand
6 F. Whisholm.

INVENTOR:

Robert T. Huggins
J. Louis Daggert & Co.
 Attorneys

(No Model.)

2 Sheets—Sheet 2.

R. T. HUGGINS.

TRICYCLE.

No. 414,046.

Patented Oct. 29, 1889.

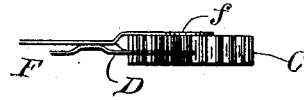
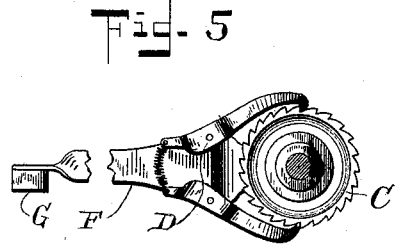
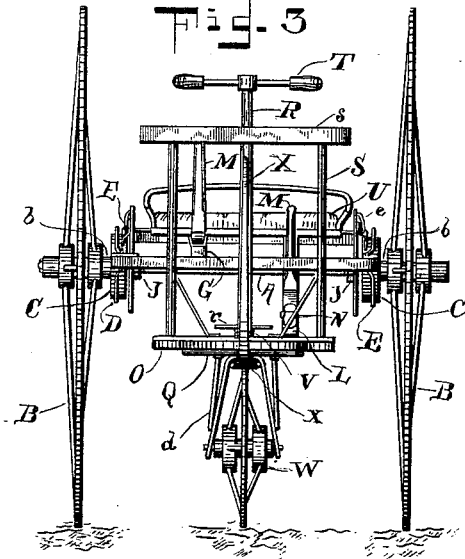
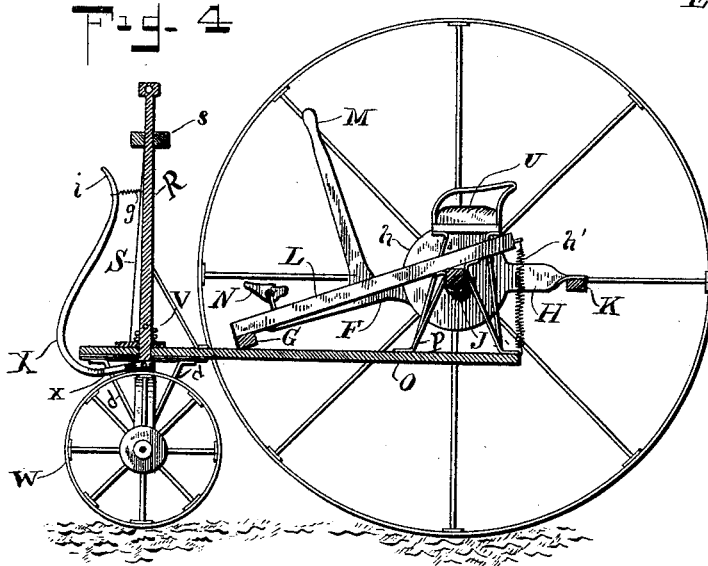
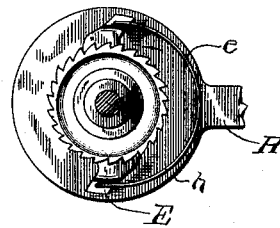

Fig. 6



WITNESSES:
F. L. Curand
C. P. Bushholm.

INVENTOR:
Robert T. Huggins
J. Sams Puffer & Co.
 Attorneys.

UNITED STATES PATENT OFFICE.

ROBERT THOMAS HUGGINS, OF FLORENCE, SOUTH CAROLINA.

TRICYCLE.

SPECIFICATION forming part of Letters Patent No. 414,046, dated October 29, 1889.

Application filed August 15, 1889. Serial No. 320,855. (No model.)

To all whom it may concern:

Be it known that I, ROBERT THOMAS HUGGINS, a citizen of the United States, and a resident of Florence, in the county of Florence and State of South Carolina, have invented certain new and useful Improvements in Tricycles; and I do hereby declare that the following is a full, clear, and exact description of the invention, which will enable others skilled in the art to which it appertains to make and use the same.

This invention relates to tricycles, and has for its object to construct a simple and substantial machine of this class, which can be operated either by the hands or the feet. I accomplish this object by the mechanism illustrated in the accompanying drawings, in which—

Figure 1 is a side elevation of the machine. Fig. 2 is a plan view of the same. Fig. 3 is a front view. Fig. 4 is a longitudinal sectional view, and Figs. 5 and 6 are detail views.

Like letters of reference denote corresponding parts in all the figures.

Referring to the drawings, the letter A designates an axle, on the arms of which turn the wheels B. These wheels are constructed, as far as the spokes and rim are concerned, in the ordinary way, the spokes being threaded at each end, the inner end screwing into the hub and the outer ends into adjustable pieces attached to the rim. To the inner end of the hub *b* of said wheels is fixed a ratchet-wheel C. Each ratchet-wheel is provided with two pairs of pawls D and E. The forward pawls D are pivoted to a forward lever F, and their forward ends are held apart by a coiled spring. Both pawls are thereby held against the ratchet-wheel, one engaging the wheel above the axle and the other below. One end of the lever F forms a washer *f*, which is placed upon the axle, and thereby the lever is fulcrumed. The forward ends of the lever F are attached one to each end of a cross-bar G. The second pair of pawls E are pivoted on the washer *h*, which forms an integral part of the lever H, and which is placed on the axle just inside the washer *f* and rests against a set-collar J. A rear cross-bar K, similar to the cross-bar G, connects the rear levers H. The pairs of pawls E are similarly placed to the pawls D, one above the

ratchet-wheels and the other under, and each has several teeth to register with the teeth of the ratchet-wheel, so that no motion shall be lost. The pawls E are made to bear against the ratchet-wheels C by the action of a semi-circular spring *e*, also attached to the washer *h*, and having its ends bear against the upper and lower of the pair of pawls E, respectively.

At a convenient distance apart two operating-levers L are fulcrumed on the axle. The lever on the left has its rear end attached to the cross-bar K, and the other lever is attached to the cross-bar G, and thus a compound lever is provided in each case. A short distance in front of the axle a handle M is fixed at right angles to each of the operating-levers L. Near the forward end of each operating-lever is fixed a pivoted pedal or foot-rest N. It will be seen that as the right operating-lever is depressed the wheels B will be turned and the machine propelled by the action of the pawls D, and, in like manner, when the left operating-lever is depressed said wheels are turned by the action of the pawls E.

From the foregoing description of the handles M and pedals N it will be evident that the levers L may be operated either by the hands or feet, at the will of the operator.

When an operating-lever is relieved from the pressure of a foot or hand, it is desirable that it shall return to its normal position, and this is accomplished by attaching a coiled or other suitable spring *h'* to each lever near its rear end and fixing the other ends of said springs to the platform O. The rear end of this platform is supported by suitable hangers P from the axle. The forward end of the platform rests upon a fifth-wheel Q, which is fixed on the vertical steering-rod R. The steering-rod passes through the platform O, through the cross-piece *s* of the vertical frame S, which rises from and is braced to the platform O, and is provided at its upper end with a steering-handle T. A short distance above the platform O a cross-rod *r* passes through the steering-rod, and by means of this the vehicle is steered by the feet when the operator works the levers L by hand. The platform O is provided with a seat U, on which the operator sits when he uses the lever-handles

M and guides the vehicle by the cross-rod *r*. This seat may be of sufficient dimensions to accommodate one or more persons, as desired. A coiled spring *V* encircles the steering-rod *R* between the cross-rod *r* and the platform *O*, and should the machine pass over uneven ground it will prevent bouncing.

Below the fifth-wheel the steering-rod is bifurcated and furnishes suitable bearings, in which the front or steering wheel *W* is journaled. This wheel is about one-third the diameter of the wheels *B* and is similar in construction, except that it has no ratchet-wheel. Suitable braces *d* are fastened to the bifurcated rod *R* and support the fifth-wheel *Q*. A brake *X* is fulcrumed to the bifurcated rod *R*, and has a broad portion or shoe *z*, which may be made to press against the rim of the wheel *W*. Beyond the shoe *z* the brake curves upward around the end of the platform and forms a handle *i*. This brace is normally kept from contact with the wheel by the tension of a coiled spring *g*, one end of which is attached to the vertical steering-rod.

Having thus described my invention, I claim and desire to secure by Letters Patent of the United States—

1. The combination, in a tricycle, of an axle, wheels revolving on said axle, ratchet-wheels fixed to the hubs of said wheels, means, substantially as described, for revolving said ratchet-wheels, a front wheel, a bifurcated steering-rod, to which said wheel is journaled, a fifth-wheel fixed on said steering-rod, a platform, and hangers connecting said steering-rod and said axle, substantially as described.

2. The combination, in a tricycle, of an axle, wheels on said axle, ratchet-wheels fixed to the hubs of said wheels, forward levers and rear levers fulcrumed on said axle, pawls pivoted to said levers and adapted to engage the teeth of the ratchet-wheel, substantially as shown, a cross-bar connecting said forward levers, a cross-bar connecting the rear levers, operating-levers fulcrumed on said axle, one operating-lever being fixed to said rear cross-bar and one lever fixed to said forward cross-bar, means, substantially as de-

scribed, for working said operating-levers, a front wheel, a bifurcated steering-rod, in which said wheel is journaled, the fifth-wheel, and a platform resting on said fifth-wheel and attached to said axle, constructed and combined substantially as described.

3. The combination, in a tricycle, of an axle, wheels adapted to turn on said axle, ratchet-wheels fixed to the hubs of said wheels, levers fulcrumed on said axle, forward pawls pivoted on the forward levers, a coiled spring adapted to keep said pawls in contact with said ratchet-wheels, rear pawls pivoted on the rear levers, a semicircular spring adapted to keep said rear pawls in contact with said ratchet-wheels, cross-bars connecting the forward and rear levers, respectively, operating-levers adapted to form with said levers compound levers and to depress said cross-bars alternately, said operating-levers having pivoted foot-pedals and lever-handles, springs adapted to bring the operating-levers back to their normal position, a front wheel, a bifurcated steering-rod, a fifth-wheel on said rod, and a platform having a seat and connecting said axle and said fifth-wheel, all constructed and combined to co-operate substantially as shown.

4. The combination, in a tricycle, of an axle, wheels on said axle, means, substantially as described, for turning said wheels and propelling the machine, a front wheel, a bifurcated steering-rod, a platform connecting said axle and said rod and having a vertical frame supporting said rod, a handle and cross-rod adapted to guide the machine with the hands or feet, respectively, a spring encircling said vertical steering-rod, a brake pivoted to said bifurcated rod, and a spring connecting said brake and vertical steering-rod, all constructed and combined to operate substantially in the manner and for the purpose shown.

In testimony that I claim the foregoing as my own I have hereunto affixed my signature in presence of two witnesses.

ROBERT THOMAS HUGGINS.

Witnesses:

P. B. BACOT,
G. L. CLIFTON.