

A. CAMERON & D. MATTHEW.  
RAILROAD WHEEL.

No. 25,317.

Patented Sept. 6, 1859.

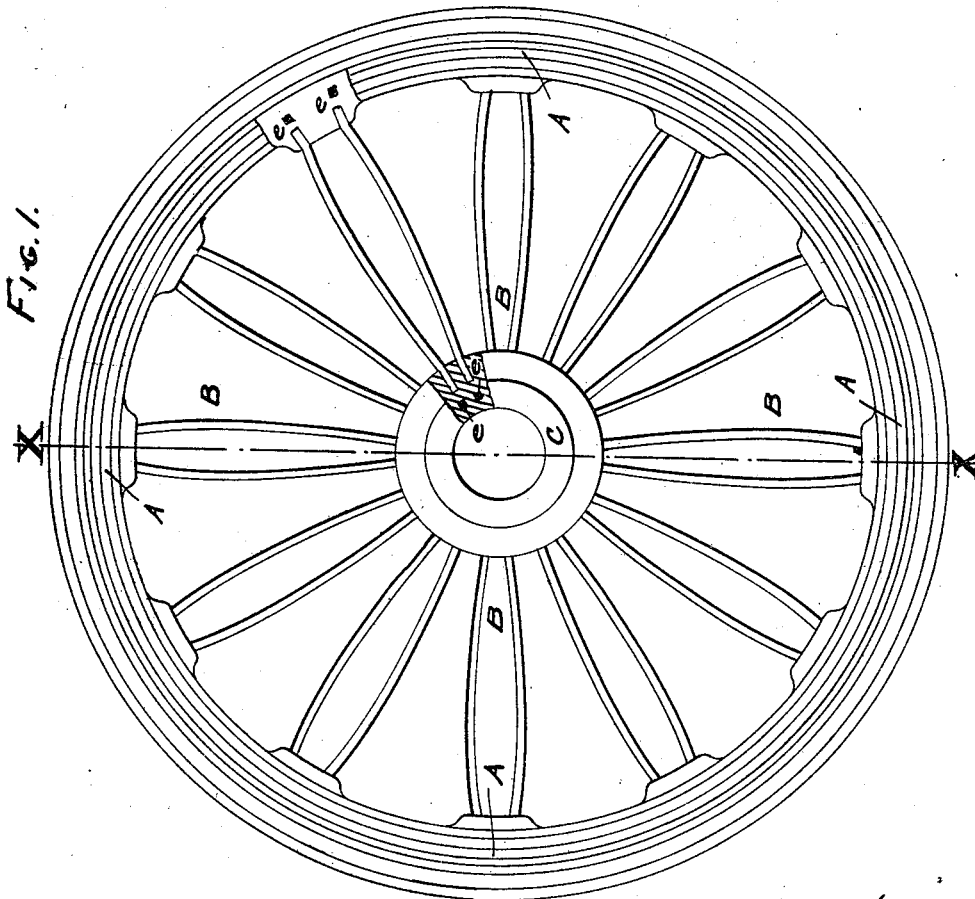
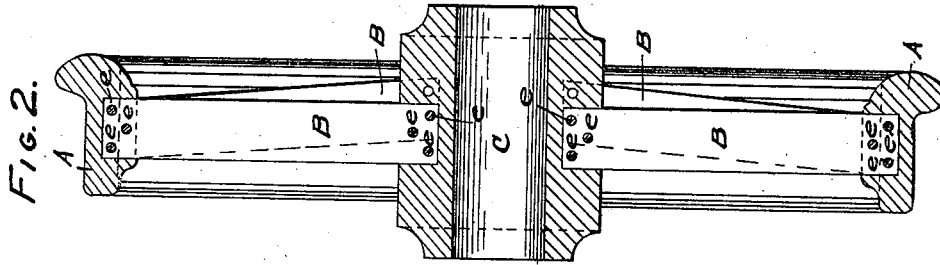

Witnesses:  
Wm. W. Taylor  
Charles D. Freeman

Inventors  
A. Cameron & Matthew

# UNITED STATES PATENT OFFICE.

ARCH. CAMERON, OF CHARLESTON, SOUTH CAROLINA, AND DAVID MATTHEW, OF PHILADELPHIA, PENNSYLVANIA.

## RAILROAD-WHEEL.

Specification of Letters Patent No. 25,317, dated September 6, 1859.

*To all whom it may concern:*

Be it known that we, ARCHIBALD CAMERON, of the city of Charleston and State of South Carolina, and DAVID MATTHEW, of the city of Philadelphia and State of Pennsylvania, have jointly invented a new and useful Improvement in Railroad-Wheels, and that the following is a full, clear, and exact description of the same, reference being had to the accompanying drawing and the letters of reference thereon.

The nature of our invention consists in the formation of a rail road car wheel, substantially as hereinafter described.

In the accompanying drawing Figure 1 is a front view of the wheel, Fig. 2 is a section through line *x, x* Fig. 1.

A is the periphery or tread, B B the arms, C the hub, *e e* hole in arms or spokes.

The manner we construct our improved elastic armed rail road wheel is to mold the wheel pattern, in the usual way, the pattern being placed in chill mold, and flask, after the usual application, of molders' tools, and work of molding, and the pattern in the mold, the pattern being removed, the arms being prepared, and in proper form, having been coated on the ends, with a flux of such a nature, as to make the fluid metal flow freely over them, and to unite, and adhere to it, and having the ends pierced with holes, to allow the metal to flow through, and unite through the arms, the arms having been properly prepared, and the mold being ready, the arms are put into a heater, and heated, and then they are placed, and secured, the metal being ready, the periphery or tread A is poured or cast, and in the course of 10 to 20 minutes' time, the hub is poured or cast, this time is to be varied, in proportion to the thickness of the periphery, and its diameter.

The following is the properties, obtained by this improved, combination in car wheels. The chill of the tread, is more uniform, and the tread, is cast of iron most suitable. The tread being chilled without any strain from other parts of the wheel, as is in other wheels, therefore has no straining of metal. The arms being curved, they are tightened by the shrinking of the hub, and yield to its requirements, this shrinkage on

the arms gives additional support to the tread, all the arms drawing to the center without having to separate or draw the particles of metal in the arms asunder. The hub is cast of iron most suitable for it. The wheel possesses elasticity, between hub and periphery, and relieves the rail from that crushing, rigidness of the common wheel, which is so destructive to rail, and rail joints on which they run. This wheel possesses elasticity, between hub and periphery, which adds materially to the protection of the shaft journal and bearings. This wheel possesses the properties of the spring, and transmits its benefits to the rail, bridges, shafts, journals and bearings.

Having thus fully described the manner we construct our improved car wheel, and the properties which it possesses, 1st, we do not claim combining curved wrought iron arms with cast hub, and cast chilled tread, when the arms, are secured thereto by keying them, in between dove tail lugs into the chilled tread, or periphery, 2nd, nor the curved arms, when the arms form a periphery for the support of a tread formed of a single ring, shrunk, or put on in any other manner separate from the arms with the hub cast on the arms, 3d, nor combining of wrought iron arms, with, cast hub, and rim, when the arms are straight, and not made to yield to the shrinkage and blows from rail joints, or other irregularities of the rails, 4th, nor do we claim the casting, of the rim first and allowing it to become quite cold, before casting, the hub, on straight wrought iron arms, as this has not the desired effect, nor do we wish to be understood, as claiming such, but

What we claim and desire to secure by Letters Patent, is—

The peculiar construction of car wheels, having elastic curved arms B, with chilled cast tread A, and cast hub C, forming one combined wheel, substantially, as herein set forth.

ARCHD. CAMERON.  
DAVID MATTHEW.

Witnesses:

JOS. JOHNSON, Jr.,  
CHARLES D. FREEMAN.